

XWS PiezoSystem

**XWS PiezoStage 100x100 &
Controller WSB PiezoDrive 4.23
Software WSB Flex Move**

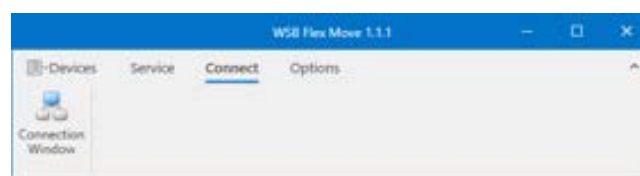
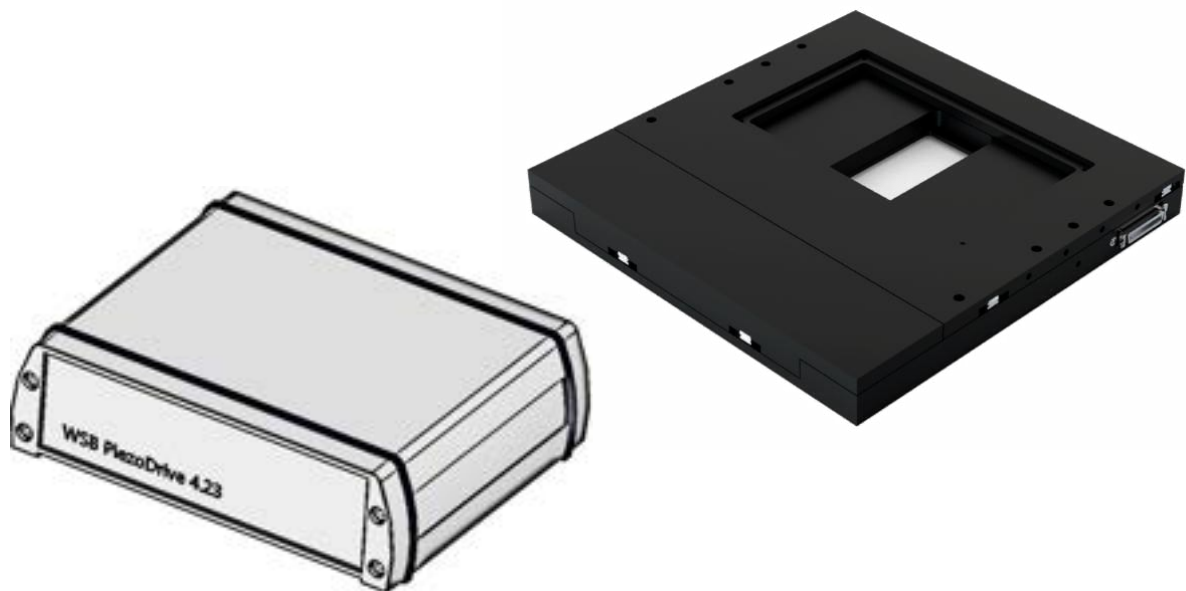

Operating Manual

Knowledge of this operating manual is essential for operating the device. Therefore, familiarise yourself with its contents and comply especially with instructions that concern safe use of the device.

We reserve the right to make changes in the interests of technical developments; however, the operating manual is not subject to the document updating service.

© Distribution and reproduction of this document, utilisation and communication of its contents are not permitted unless expressly authorised. Infringements create liability for damages.

All rights for registration of patents or petty patents reserved.

All companies and products mentioned in this operating manual may be the subject of a trademark or registered trademark. Non-proprietary products are mentioned only for information. This does not constitute approval or recommendation.

Issued for Xeryon BV
Diestsesteenweg 692
3010 Leuven, Belgium

Number of this manual: V2.03
Date of issue: Version: 10th February 2026

Content

1	Scope of delivery	4
1.1	Overview scope of delivery of XWS PiezoSystem	4
1.2	Instructions for the use of the device	5
1.3	General instructions	5
1.4	Guarantee information	7
2	System components	8
2.1	General	8
2.2	Controller WSB PiezoDrive 4.23	8
2.3	XWS PiezoStage 100 x 100	9
2.4	WSB Flex Move – control software	9
3	Commisioning	9
3.1	Connection of the WSB PiezoDrive 4.23 to the XWS PiezoStage 100 x 100	9
3.1.1	Connection	9
3.1.2	Switch on	10
3.1.3	Not in use / switch off	10
3.2	WSB Flex Move – control software	10
3.2.1	Setup and Installation	10
3.2.2	Connection to the controller	11
3.2.3	Control of ther XWS PiezoStage 100 x 100	12
3.2.4	Operation buttons of the Control center	13
3.3	Mounting of the PiezoStage on constomer-specific mount	13
3.4	Insert insert plate	14
3.5	Manual operation the a joystick (option)	14
4	Technical Data	14
4.1	Key features	14
4.2	Controller data	14
4.3	Motion performance	14
4.4	Mechanical properties – stage	15
4.5	Environmental compatibility	15
4.6	Dimensional drawings	16
4.6.1	Stage	16
4.6.2	Inserts of upper plate – options	17
5	Care and Maintenance	18
5.1	Care	18
5.2	Changing the power supply unit	19
6	Transport	19
7	Disposal	19
8	Troubleshooting	20
9	Customer Service	20

1 SCOPE OF DELIVERY

1.1 Overview scope of delivery of XWS PiezoSystem

No.	pieces	Declaration	
1	1	XWS PiezoStage 100 x 100	
2	1	WSB PiezoDrive 4.23 xy controller	
3	1	Cable MDR 36pol. to D-SUB HDD 44pol. 2,5m (connection between xy-PiezoStage and controller)	
4	1	Mains cable, black, 2m, Protective contact 90° - C13 180° (connection power supply unit and mains socket)	
5	1	Power supply unit TRH50A240-62E13 VI with R7B plug (connection mains cable and controller)	
6	1	USB cable 2.0, grey, 2m, plug A to plug B (connection controller to PC)	
7	1	Mounting kit (9900140) for the stage consisting of: - 4x ISO 7380-1 fillister head screw with hexagon socket, M6x10; - 1x hexagon wrench 4 mm	Without picture
8	1	Software WSB Flex Move for XWS (download)	Without picture
Options			
9	1	Stage insert plate for the top plate of the sage	See chapter 4.6.2
10	1	Mounting kit for the insert plate (top) consisting of: - 1x hexagon wrench 2 mm, - 4x DIN 7991, countersink screws with hexagon socket, M3x6	Without picture

1.2 Instructions for the use of the device

The XWS PiezoStage 100 x 100 and the Controller WSB PiezoDrive 4.23 are designed and built exclusively for use together. They are used for quick software-aided positioning in the x-y direction.

1.3 General instructions

The XWS system has been designed, built and tested in accordance with DIN EN 61010-1 (IEC 61010-1) "Safety requirements for electrical equipment for measurement, control and laboratory use".

The system satisfies the EC Low Voltage Directive 2014/35/EU, the EMC Directive 2014/30/EU, the RoHS Directive 2011/65/EU and is marked with the  symbol.

Proof of conformity is based on the following standards:

- EN 61010-1:2020-03
- EN 61326-1:2021
- EN 63000:2018

The devices must be disposed of in accordance with the WEEE Directive 2012/19/EU.

This operating manual contains information and warnings which must be heeded by the operating company.

The paragraphs below list the warning and instruction symbols that are used in this operating manual.



CAUTION

This symbol indicates a hazard which may arise for the user.



CAUTION

Before accessing inside the system, withdraw the mains plug!



ATTENTION

This symbol indicates a hazard which may arise for the device or the system.



NOTE

This symbol indicates a note which should be observed with special care.



ATTENTION

Crushing hazard!

Warning and safety instructions



The manufacturer accepts no liability if the system is used other than for the intended purpose, either as an individual module or as a free-standing unit. This applies also to all service or repair work undertaken by anyone other than authorised service personnel. Breach of these conditions will cause the guarantee and warranty to become void.



Closing off or covering the ventilation slots can lead to a build-up of heat which can damage the device and in an extreme case cause fire. Always keep the ventilation slots clear. Do not insert objects into them or allow objects to fall into them. Such insertion can lead to electric shock or short circuits.



The mains plug may be inserted only into a socket with an earth contact. The earth protection must not be invalidated by use of an extension lead lacking an earth conductor.



A Removable mains cables must not be replaced with mains cables that are inadequately sized. Only the specified mains leads may be used.



Before accessing inside the system, always withdraw the mains plug for the table-top power supply unit from the mains socket.



Only trained electricians or the manufacturer's service engineers are permitted to open the device.



The power supply unit of the controllers WSB PiezoDrive 4.23 is approved for use without any additional voltage converters on mains voltages in the range 100 to 240 V \pm 10%, 50 to 60 Hz.



Before inserting the mains plug, check that the mains supply voltage matches the value shown on the device nameplate.



The power supply unit of the controllers WSB PiezoDrive 4.23 must not be allowed to come into contact with moisture. If the casing becomes damaged, take the power supply unit out of service. The controller may be operated only in conjunction with the power supply unit provided.



Never withdraw the mains plug whilst the device is in operation. To switch the device off, use the On/Off switch.



Operation of the device in a explosion hazard environment is not permitted.



When using the XWS PiezoStage 100 x 100 the maximum load of 3 kg must not be exceeded. Otherwise the stage attachment may not operate correctly and may be damaged beyond repair.



The contacts of the x-y connection sockets on the WSB controller must not be touched. A voltage of 90 Veff / 85 kHz may be applied.



Switching off at the ON/Off switch (Fig. 1/1) switches off only the internal controller. The mains power supply to the table-top power supply unit is not switched off. If the controller is not going to be used for some time, withdraw the mains plug for the power supply unit from the socket.



Do not reach into the possible travel path of the motorised XWS PiezoStage 100 x 100 with your hands. There is a risk of crushing and injury to hands.



The devices are not provided with any particular protection against corrosive, potentially infectious, toxic or radioactive samples, or against any other samples that may be hazardous to health. All statutory requirements, in particular the national regulations for accident prevention, must be complied with when handling such samples.



For transport over fairly long distances the device must be partially dismantled and packaged in the original packaging, therefore the original packaging should be kept for future use.



When handling the piezo stage (e.g. removing it from the transport packaging), ensure that the piezo stage is always held horizontally to prevent uncontrolled movement of the positioning axes, which could have a negative impact on the precision properties of the stage.



Do not dispose of defective devices in domestic rubbish; they must be disposed of in accordance with the statutory regulations.

1.4 Guarantee information

The device manufacturer guarantees that the device when delivered it is free of material and manufacturing defects. Any defects that occur must be reported immediately, and everything must be done to limit the extent of the defect. If such a defect is reported, the device manufacturer undertakes to make good the defect, by either repairing the device or replacing it with a new one free of defects. No warranty is given for defects arising from natural wear and tear (in particular affecting wearing parts) or from improper use.

The device manufacturer accepts no liability for damage arising from incorrect operation, negligence or tampering with the device, in particular arising from removal or exchange of parts of the device or the use of accessories from other manufacturers. In such cases all claims under warranty are void.

With the exception of the activities described in this operating manual, no maintenance or repair work may be performed on the controller. Repairs may be performed only by Customer Service or specially authorised persons.

2 SYSTEM COMPONENTS

2.1 General

The XWSPiezo-System consists of the WSB PiezoDrive 4.23 controller, an XWS PiezoStage 100 x 100 and the WSB Flex Move control software. The PiezoStage and a PC can be connected to the controller using the associated cables. The controller enables fast, precise positioning of objects attached to the PiezoStage in the x and y directions, which can be controlled using the WSB Flex Move software. Optionally, it is possible to control the movements using a joystick.

2.2 Controller WSB PiezoDrive 4.23

On the back plane of the WSB PiezoDrive 4.23 controller are all connections, switches and displays.

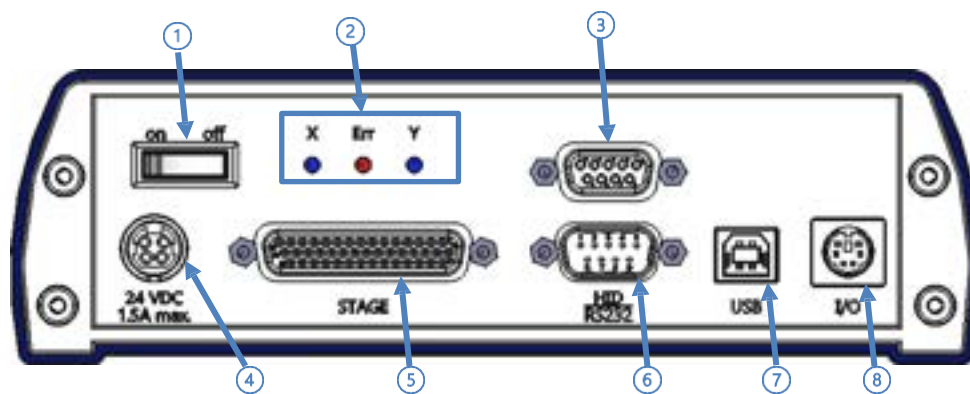

figure 1

no.	description
1	on/off: On/Off switch for the controller
2	Indicator LED "X" (blue): x-axis is active
	Indicator LED "Err" (red): error
	Indicator LED "Y" (blue): y-axis is active
3	HID: connection to HID devices without a PC, e.g. joystick
4	24 VDC/ 1.5 A max.: DC voltage socket

no.	description
5	Stage: connection to the PiezoStage
6	RS232: connection to a PC
7	USB: connection to a PC
8	I/O: In/Out – trigger- input/output
	Type label (at the bottom of the casing)

2.3 XWS PiezoStage 100 x 100

The XWS PiezoStage 100 x 100 consists of three plates:

- 1 X-positioning axis (upper, red plate in this picture)
- 2 Y- positioning axis (middle, green plate in this picture)
- 3 Mounting plate (lower, grey plate in this picture) with mounted insert plate

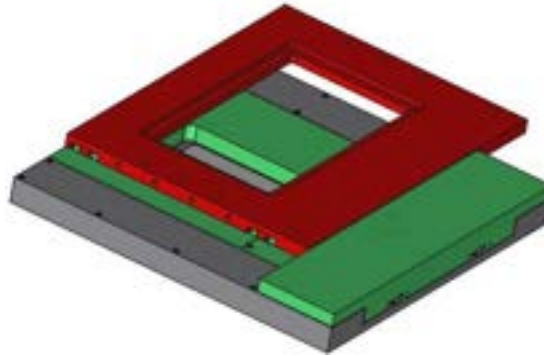

- The PiezoStage has various threaded holes on the upper plate that allow test objects to be attached. In addition, various inserts can be used (see section 5.7.2).
- The PiezoStage has various threaded holes in the lower mounting level, which enable mounting on customer-specific perforated grid plates (see dimensional drawings) as well as on various microscope stage supports (on request) by means of adapters. In addition, a lower insert is mounted that can be dismantled for special applications.

2.4 WSB Flex Move – control software

This software is used for manual referencing and individual positioning of the XWS PiezoStage 100 x 100.

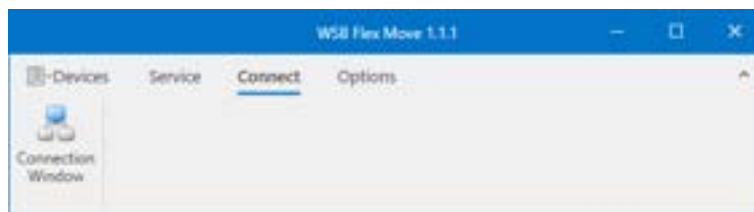

3 COMMISSIONING

3.1 Connection of the WSB PiezoDrive 4.23 to the XWS PiezoStage 100 x 100

3.1.1 Connection

- Make sure the controller is switched off, the in-/out-flip switch is "off" (figure 1/1).
- The 44-pin. Plug the connection cable (scope of delivery no. 3) to the socket "Stage" on the controller and with the 36-pin socket to the only interface on the PiezoStage.
- Connect the USB cable (scope of delivery no. 6) to the USB socket of the controller and to a free USB interface of the PC, alternatively use the RS232 interface.
- Connect the power supply (scope of delivery no. 5) to the voltage socket (figure 2/4) of the controller with the R7B power supply plug.
- Connect the mains cable (scope of delivery no. 4) to the mains connection socket (see below) of the power supply unit.
- Plug the mains cable into the supply socket.

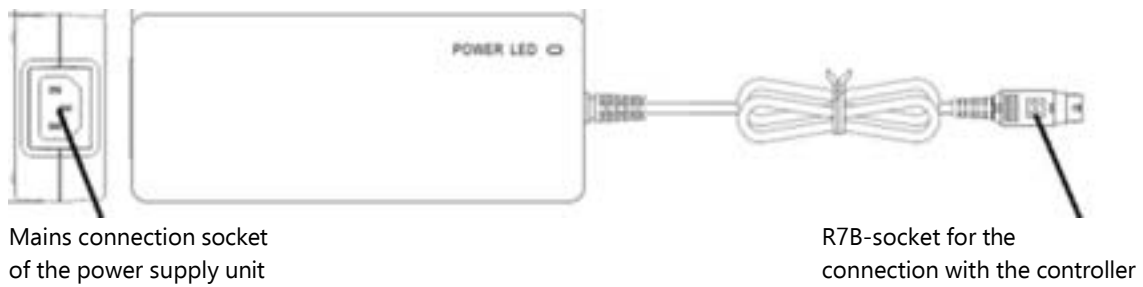

figure 2

3.1.2 Switch on

- Set the on/off switch (figure 1/1) on „on“.

3.1.3 Not in use / switch off

- Turn off the controller after each use with the on/off switch (figure 1/1).
- If the controller is not used for a long time, the power plug of the power cord should be removed from the socket so that it is disconnected from the mains voltage.
-

3.2 WSB Flex Move – control software

3.2.1 Setup and Installation

For the first installation, the provided **"Setup – WSB Flex Move"** must be executed on the PC that is to be connected to the controller and in the last step the drivers listed below must be installed.

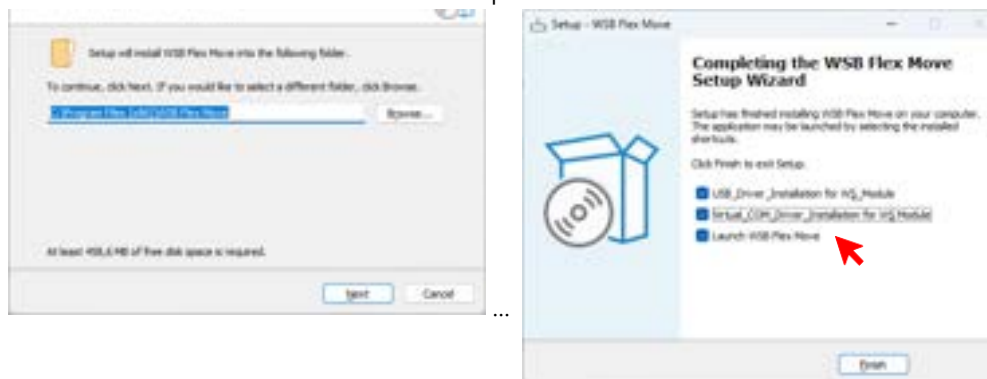

A shortcut icon can be set up on the desktop to start the **"WSB Flex Move"** program by double-clicking on the next applications.

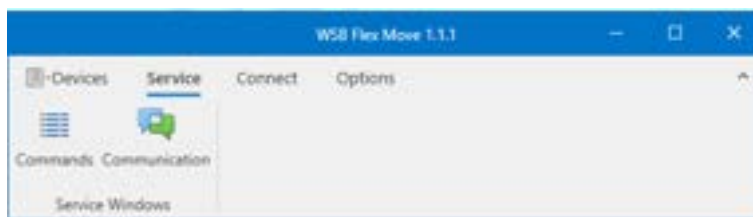
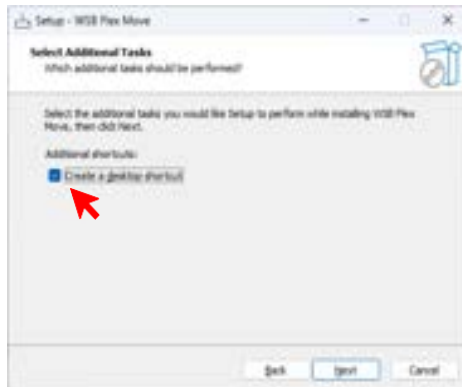

3.2.2 Connection to the controller

- Select the menu item „Connect“ and then „Connection Window“:

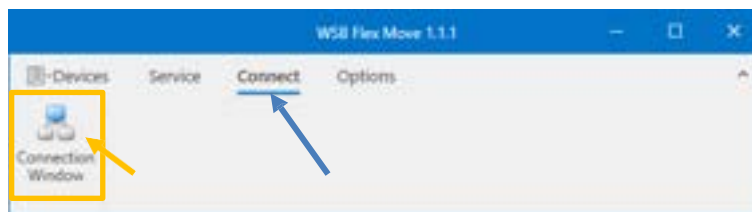

- The „Connection“ window opens. Here click on „Search“.

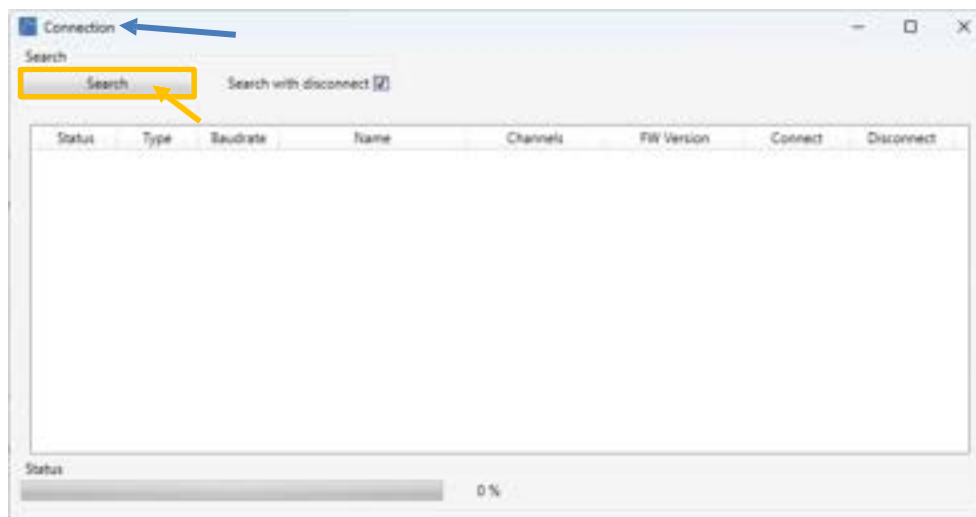

- The found devices are shown as „Inactive“.



- Choose "PiezoDrive" on COM3 (or another device) and click „Connect“.

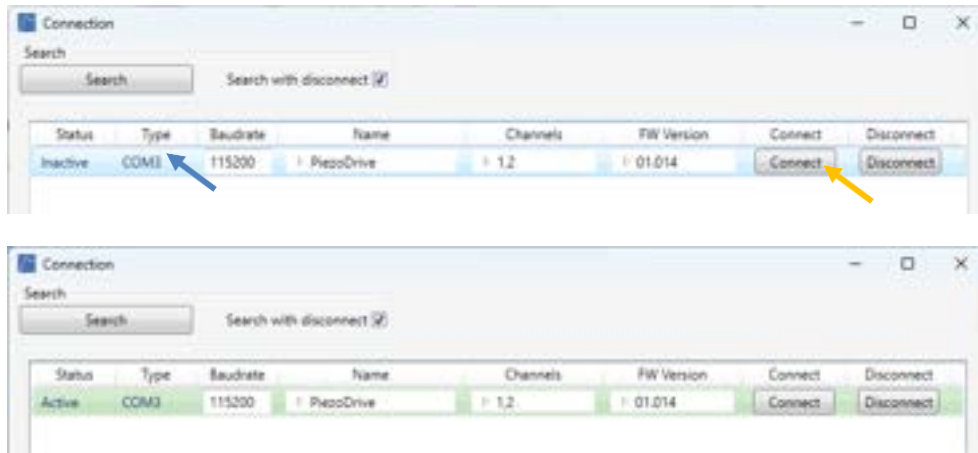

3.2.3 Control of the XWS PiezoStage 100 x 100

- Click on the menu item „Devices“. The „Controlcenter“ is shown.

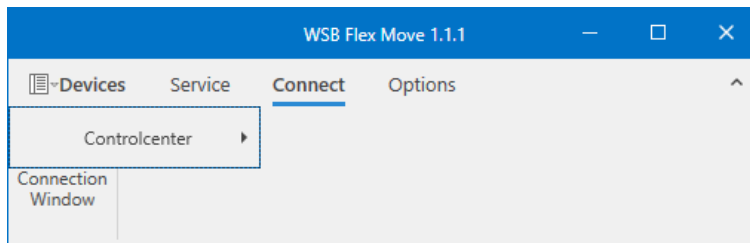

- With „Mouse over“ the available axes of the connected, active device will be shown. Ch 1 is the x-axis and Ch 2 is the y-axis.



- Click on 'UltrasonicPiezo Ch 1' to open the control window for the x-axis
- Click on 'UltrasonicPiezo Ch 2' to open the control window for the y-axis





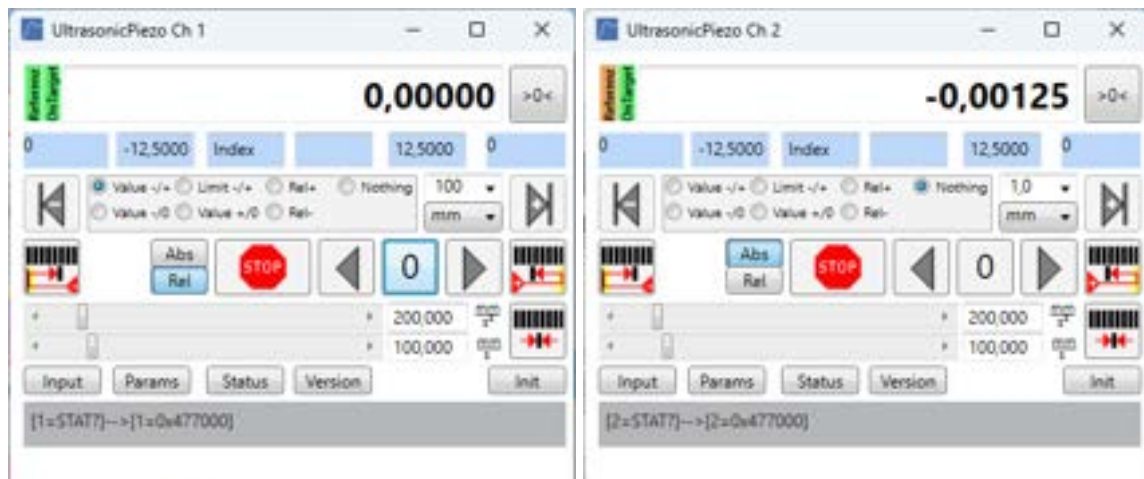









Level

- 1
- 2
- 3
- 4
- 5
- 6
- 7

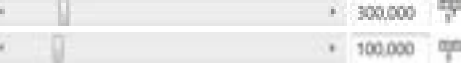

- Both windows can be positioned next to each other or below each other on the screen.

3.2.4 Operation buttons of the Control center

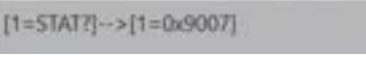
Level	description				
1	Referenz: Indicates whether the axis is referenced (green = yes)		OnTarget: Indicates whether axis has reached target position (green = yes)		Numbers: Axis position counter (mm)
	 Manual zero / Move/set coordinate system; Set current position as zero position (see position counter)				
2	Hardware limit switch (-) / Software limit switch (-) (writeable) / Index → currently inactive / Empty → currently inactive / Software limit switch (+) (writeable) / Hardware limit switch (+)				
3	 Manual movement to hardware limit switch (-) (+) In case stage has hardware limit switches				
	Value -/+: Continuous movement between negative and positive calibration value		Limit -/+: Continuous movement between negative and positive software limit switch		Rel +: Relative movement in the step size of the calibration value in the positive direction till the end
	Value -/0: Continuous movement between negative calibration value and 0		Value +/0: Continuous movement between positive calibration value and 0		Rel -: Relative movement in the step size of the calibration value in the negative direction till the end
	 Nothing: Switch off continuous movements		 Calibration value of the movement (step size and unit)		
4	 Reference movement to the centre approached from the left or right				
	 Activate absolute or relative positioning			 Stop axis	
	Manual movement (absolute or relative) with distance and unit from ComboBoxes above (level 3 Calibration of the movement)			 Move axis to zero position	
5	 Acceleration Velocity			 Manual index search	
6	 Query inputs of the axis	 Opens the axis parameters window	 Query status of the axis	 Query the firmware version of the axis	 Opens a window for sending manual commands to the axis
	 [1=STAT?]->[1=0x9007]				
7	Indicator of the last communication with the axis				

3.3 Mounting of the PiezoStage on customer-specific mount

The PiezoStage can be attached to a customer-specific perforated grid plate (not included) with four M6x10 screws (ISO 7380) and hex key 4 mm included in the scope of delivery.

The mounting holes are intended for M6 hole grids with a distance of 25x25 mm. The y-axis must be moved into the front or rear stop for assembly so that the holes can be accessed.

The PiezoStage must be mounted so that the cable outlet is located at the rear right when viewed from the front.



Fix the screws loosely for the time being and then tighten them crosswise.

3.4 Insert insert plate

Different insertion plates (optional) for the PiezoStage are available to enable flexible mounting options for objects.

Put the insert plate into the opening of the upper plate and fixed in the upper plate by means of 4 pieces of M3x6 screws (DIN 7991) and hex key 2 mm. The symmetry of the panel prevents incorrect assembly. Insert carefully and fix the screws loosely for the time being and then tighten them crosswise.

3.5 Manual operation the a joystick (option)

Therefor connect the optional joystick to the HID socket.

4 TECHNICAL DATA

4.1 Key features

drive principle	patented Crossfixx™ ultrasonic piezo technology
bearings	precision linear recirculating roller
lifetime distance	> 1000 km / typ. 20 million cycles
control principle	closed-loop position control
Model code structure	Encoder resolution: 1000 nm or 250 nm or 50 nm

4.2 Controller data

Interfaces		General parameters	
RS232	1 x	Power consumption	Max. 15 W per axis
USB	1 x	Operating temperature	10-60°C
I/O Trigger	MiniDin: 2x In; 2x Out 5V (TTL)	Dimensions HxWxD	58x190,4x150 mm
Stage	D-Sub HD 44	Weight	Ca. 1,4 kg
HID	D-Sub 9		

4.3 Motion performance

		resolution	-1000	-250	-50	unit	tolerance
ENCODER	type	optical, incremental					
	grating period	20			µm		
	resolution	1000	250	50	nm		
	index	1 per full stroke					
	accuracy	± 10	± 5	± 1	µm	typ.	
STAGE	positioning	resolution = min. step size = min. incremental motion (MIM)	1	1	1	enc. count	typ.
		unidirectional repeatability	± 1	± 1	± 1	enc. count	typ.

resolution		-1000	-250	-50	unit	tolerance	
	bidirectional repeatability	± 2	± 2	± 2	enc. count	typ.	
	speed	max. speed			250	mm/s	typ.
		min. speed			5	µm/s	typ.
		stability (at typical speed of 10 mm/s)			± 1	%	typ.
		point-to-point positioning time for a 1 mm step ¹	(without load)		300	msec	typ.
		point-to-point positioning time	10 mm	300	450	msec	typ.
	1 mm	150	225	msec			
	100 µm	100	150	msec			

¹ settling within bidirectional repeatability range

4.4 Mechanical properties – stage

XWS (all models)		unit	tolerance	
Dimensions stage	length	215	mm	
	width	215		
	height	24,9		
stroke / travel range	standard cage	100 x 100	mm	± 0.1
max. acceleration (without load)		1	m/s ²	typ.
mass (w/o connector)		2,5	kg	± 5%
load capacity (payload limitation)		3	kg	max.
driving force		5	N	min.
holding force		5	N	min.
passive holding stiffness (XY)		1	N/µm	typ.
stage material	slider/base	aluminium, black anodized		
cable length		2	m	± 0.1

stage inserts (options)

- M6 breadboard insert
- Blank breadboard
- Xeryon stage insert (for adding additional axes)
- Other inserts upon request

4.5 Environmental compatibility

temperature range	-30°C to +70°C (transport) +10°C to +40°C (operation)
humidity range	max. 75% RH (non-condensing)
heat dissipation (motor only)	< 5 W
mounting surface flatness	< flatness specification of stage

4.6 Dimensional drawings

4.6.1 Stage

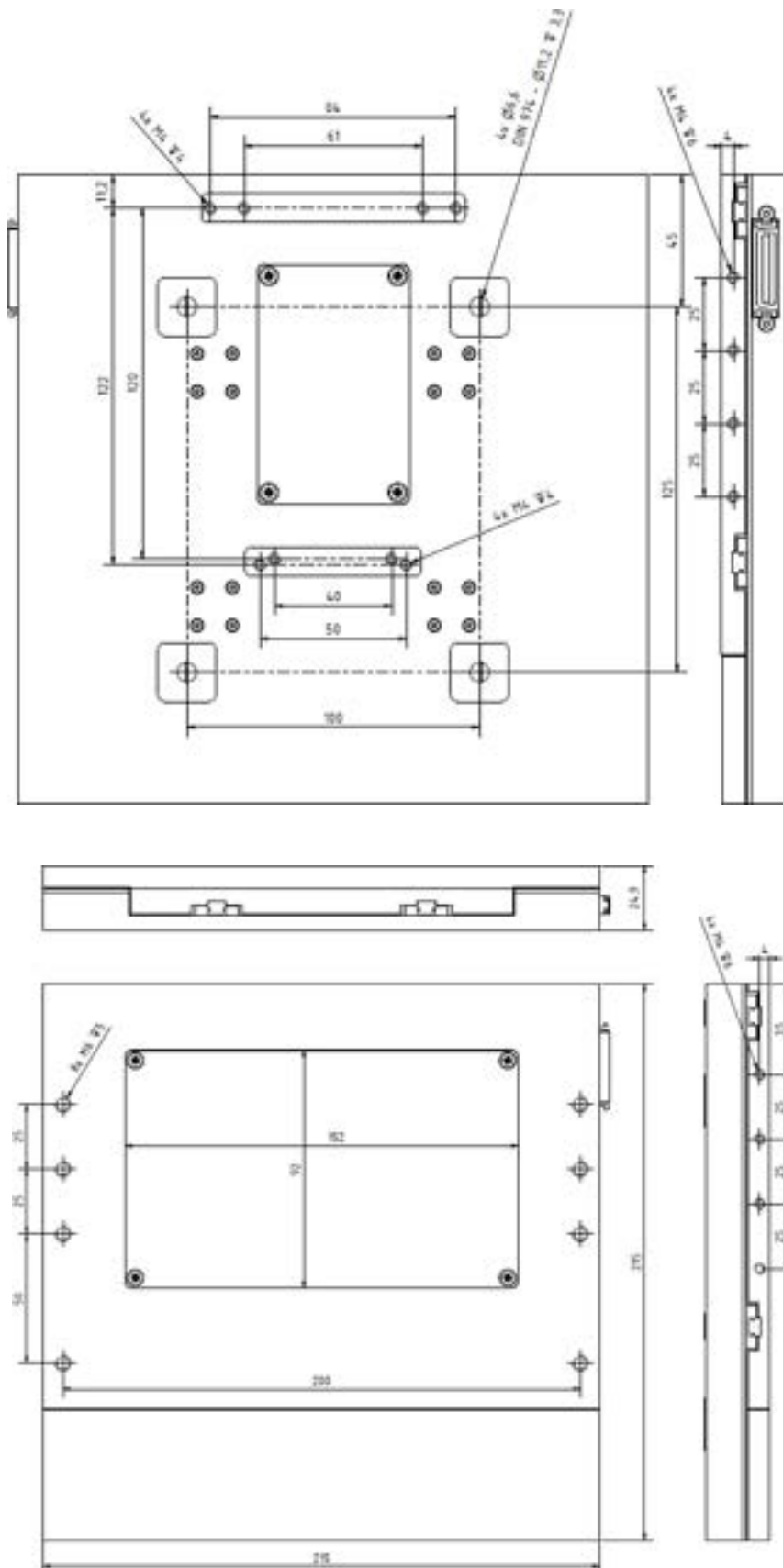

4.6.2 Inserts of upper plate – options

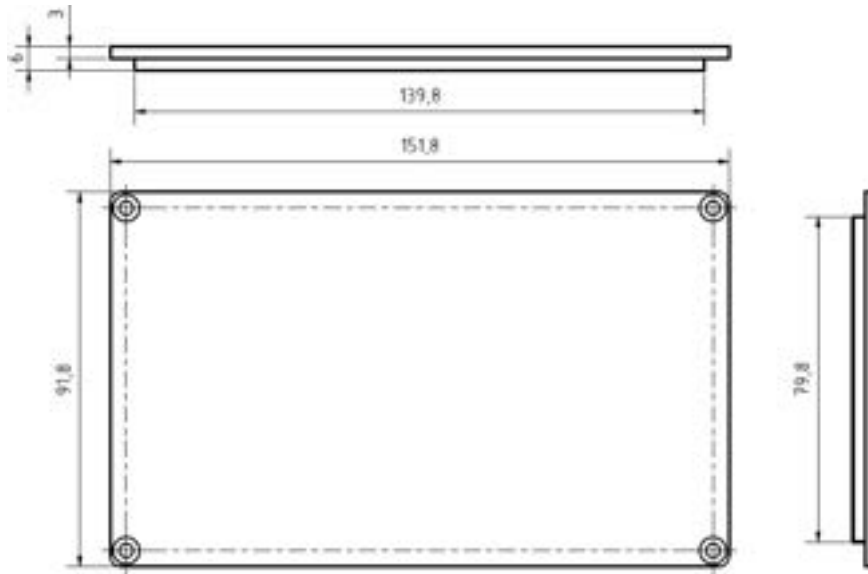

Id-No. 5005131: Insert Blank

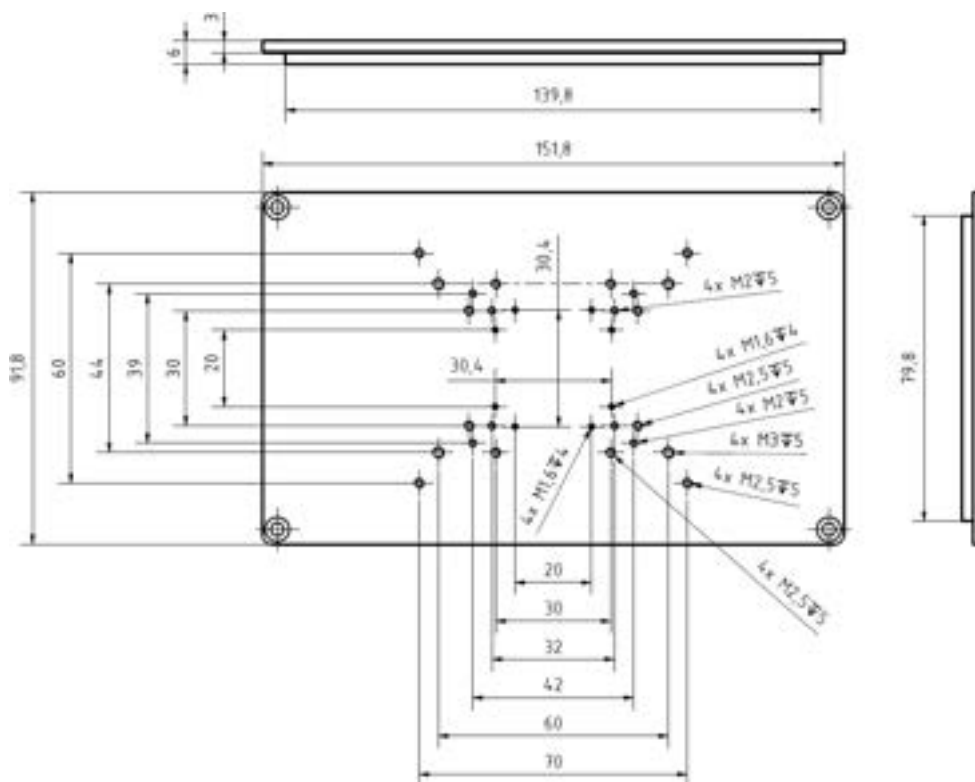

Id-No. 5005130: Insert Xeryon breadboard

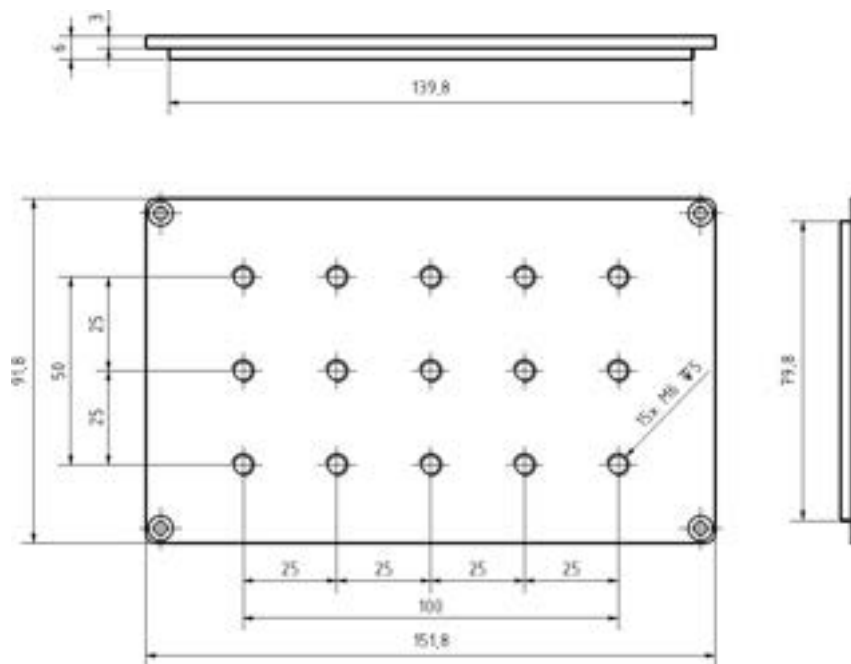

Id-No. 5005132: Insert M6 breadboard

5 CARE AND MAINTENANCE

5.1 Care



Before cleaning them, disconnect the devices from the mains. Make sure no cleaning fluids penetrate inside the devices.



The devices are not provided with any particular protection against corrosive, potentially infectious, toxic or radioactive samples, or against any other samples that may be hazardous to health. All statutory requirements, in particular the national regulations for accident prevention, must be complied with when handling such samples.

Care of the devices is restricted to the work listed below:

- Remove dust and visible dirt using a brush, blower brush, cotton bud, lens paper or cotton cloth.
- When removing contamination from the device, comply with the regulations for accident prevention.
- Do not allow any liquids to penetrate inside the device.
- Remove water-soluble dirt (coffee, cola etc.) by first breathing on it then wiping it with a non-linting cotton cloth or a moistened cloth. If desired the moistening can be with a mild cleaning fluid instead of water.
- Wipe off heavier deposits of dirt (immersion oils, fingerprints) with a cotton bud or non-linting cotton cloth using lens cleaning fluid mixture L.

This cleaning mixture consists of 90 vol% petrol and 10 vol% isopropanol (IPA). The individual constituents are also known as the following synonyms:

Petrol: Surgical spirit, petroleum ether

Isopropanol: 2-propanol, Di-methyl carbinol, 2-hydroxy propane

5.2 Changing the power supply unit



Only the table-top power supply unit specified by the manufacturer may be used.

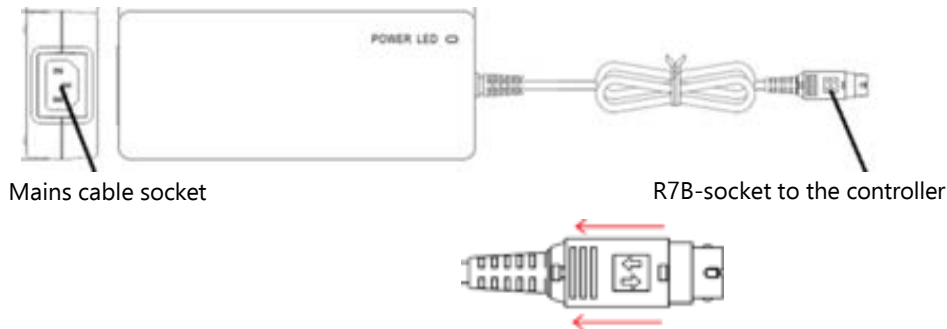

figure 3



Before accessing inside the system, always withdraw the mains plug for the table-top power supply unit from the mains socket.

To replace the table-top power supply unit, proceed as follows:

- Disconnect the mains plug of the mains cable out of the socket.
- Disconnect the R7B-power supply unit plug from the DC voltage socket (figure 1/4). Therefore pull the lock release in the direction of the arrows (figure 3) to release the R7B power supply unit plug.
- Connect the new power supply unit using the R7B power supply unit plug into the DC voltage socket on the controller (figure 1/4.)
- Plug the mains cable into the power supply socket of the power supply unit.
- Insert the mains plug of the power supply unit into the mains supply socket.

6 TRANSPORT

For transport over c long distances the system must be dismantled into its components as supplied and packaged in the original packaging, therefore it is essential the original packaging is kept for future use. For dismantling, proceed as follows:

- Switch the controller off at the On/Off switch.
- Disconnect the system from the power supply by withdrawing the mains plug for the table-top power supply unit from the supply socket.
- Remove any sample from the insert frame
- If necessary, remove the PiezoStage from the customised holder.
- Disconnect the connection cable between the PiezoStage and controller and all other connection cables.
- Place the PiezoStage, controller and power supply unit in the original packaging provided.
- Close the original packaging.

The system can safely be transported only when it is packed in the original packaging. The manufacturer accepts no liability for damage resulting from unsuitable packaging.

7 DISPOSAL



The symbol alongside means that the XWS PiezoSystem is classified as an electrical or electronic device under the EU Directive 2012/19/EU (WEEE-Reg.-Nr.: DE 78467234) and therefore must not be disposed of together with ordinary household waste.

All devices manufactured by Wienecke & Sinske can be sent back to Wienecke & Sinske for disposal free of charge:

Wienecke & Sinske GmbH
 Heiligenstädter Straße 78
 37130 Gleichen-Bremke (Germany)
 (WEEE-Reg.-No.: DE 78467234)



If you dispose of the system yourself, comply with the local laws and regulations.

8 TROUBLESHOOTING

Description of the fault	Cause of the fault	Remedy for the fault
	No power supply	Controller is not switched on
	No power supply	Establish a power supply; Switch „on“
Controller does not respond	Power supply unit defective	Exchange the power supply unit (see chapter 5.2)
	Electronics defective	Contact Customer Service
Red LED “Err” is active	System error	Send command [0=ERR?]
		(see Error Code Chapter in the Programming Manual)

9 CUSTOMER SERVICE

The staff at Xeryon will be happy to help you with support enquiries, complaints and suggestions regarding the piezo system and additional services.

You can reach customer service via:

Xeryon BV
 Diestsesteenweg 692
 3010 Leuven, Belgium

[+32 16 90 39 04](tel:+3216903904)
info@xeryon.com

For technical support:

support@xeryon.com

So that we can help you quickly when you require service, please have the following information about your system ready to hand. This can be found on the nameplates of the components:

- Type
- S/N (Serial No.)
- Art. No. (Article No.)