

## XRT-U series

### Compact and fast rotation stage

The XRT-U is a compact and fast rotation stage driven by an ultrasonic piezo motor. Xeryon's ultrasonic piezo motor ensures you high speeds, long lifetime and noiseless operation. This makes the XRT-U a state-of-the-art rotary stage for a broad range of precision positioning and metrology applications. The precision ball bearings allow you to achieve low error motion values. The XRT-U is available in four sizes and with different options. Stacking onto a Xeryon linear stage is easily done directly on the top plate or with available interface plates.

#### Key features

drive principle	patented Crossfixx™ ultrasonic piezo technology
bearings	precision ball bearings
lifetime	>1000 km / typ. 10 million rev.
control principle	closed-loop position control
input voltage	48 V

#### Model code structure

stage type	approx. rotor diameter (mm)	encoder resolution (μrad)	optional		connector type
			vacuum compatibility	non-magnetic	
XRT-U	-25	-109 -49 -19 -3	-HV (10 <sup>-6</sup> mbar) -UHV (10 <sup>-9</sup> mbar)	-NM	see table below
	-30				
	-40				
	-60				

connector option	standard	-HV	-UHV
-C0	flying leads (12x + shield)		
-C1 (default)	1x 15p D-sub HD male	1x 15p D-sub female	
-C2	1x 12p Fischer (S 103 Z062-130+)		not possible

## Environmental compatibility

temperature range	-30°C to +70°C
humidity range	20% to 90% RH (non-condensing)
heat dissipation (motor only)	< 1 W (XRT-U-30/40) < 1 W (XRT-U-25 single motor) < 2 W (XRT-U-25 dual motor) < 5 W (XRT-U-60)
mounting surface flatness	< 20 µm
internal operation voltage	< 48 V

## Motion performance

### 1. Specifications dependant on the encoder resolution (x = diameter)

		XRT-U-x-109	XRT-U-x-49	XRT-U-x-19	XRT-U-x-3	unit	tolerance
ENCODER	type	optical, incremental					
	resolution	109 22.5 6250	49 10.1 2810	19 3.92 1090	3 0.62 170	µrad arcsec µ°	
	index	1 per rev.					
	scale accuracy	± 0.017				%	typ.
STAGE positioning	resolution = min. step size = min incremental motion (MIM)	125 25 7100	50 10 2800	25 5 1400	15 3 860	µrad arcsec µ°	typ.
	unidirectional repeatability	± 125 ± 25 ± 7100	± 50 ± 10 ± 2800	± 25 ± 5 ± 1400	± 15 ± 3 ± 860	µrad arcsec µ°	typ.
	bidirectional repeatability	± 250 ± 50 ± 14200	± 100 ± 20 ± 5600	± 50 ± 10 ± 2800	± 30 ± 6 ± 1720	µrad arcsec µ°	typ.

### 2. Specifications dependant on the diameter

		XRT-U-25	XRT-U-30	XRT-U-40	XRT-U-60	unit	tolerance	
STAGE	speed	max. speed	1080	720	540	360	°/s	typ.
		min. speed	0.008	0.008	0.006	0.004	°/s	typ.
		stability	1				%	typ.
		point-to-point positioning time* 0 kgmm <sup>2</sup> inertia 65 kgmm <sup>2</sup> inertia	30 150				msec	typ.
		max. acceleration	1370	276	96	51	x10 <sup>3</sup> °/s <sup>2</sup>	typ.
	error motion (p-p)	radial at 7 mm above top surface	5	1	2	5	µm	max.
axial in centre		2.5	0.5	1	2.5	µm	max.	
tilt (wobble)		250	50	100	250	µrad	max.	
	operation duty cycle (for -HV/-UHV only)	50				%	max.	
		120				sec	max.	

\* for a 1° step and settling within bidirectional repeatability range

Note: a detailed description of the technical terms used in this datasheet can be found on the Terminology page of our website.

Last updated: 15/10/2024. All specifications are subject to change without prior notice.

### 3. Exact counts per revolution in function of encoder resolution and rotor diameter

		XRT-U-25	XRT-U-30	XRT-U-40	XRT-U-60
resolution (µrad)	109	57600	57600	86400	64800
	49	144000	144000	135000	129600
	19	360000	360000	345600	324000
	3	1843200	1843200	2764800	2073600

### Mechanical properties

		XRT-U-25	XRT-U-30	XRT-U-40	XRT-U-60	unit	tolerance
dimensions		37.5 x 30 x 8.9	40 x 35 x 21	50 x 46 x 21	70 x 70 x 38.6	mm	± 0.1
rotor diameter		27	32	43	65	mm	± 0.1
aperture		6.35	7	13.5	25.4	mm	± 0.1
rotation range		> 360° (unlimited)					
mass (w/o connector)		25	82	130	450	g	± 5%
load capacity (payload limitation)	inertia	50	300	400	2500	kgmm <sup>2</sup>	max.
	mass*	0.1	0.5	1	5	kg	
load capacity (bearing force limitation)	axial	10	25	35	100	N	max.
	radial	10	25	35	100	N	
	tilt	0.05	0.15	0.2	1	Nm	
driving torque		9.5 (single motor) 19 (dual motor)	15	20	90	mNm	min.
holding torque		9.5 (single motor) 19 (dual motor)	15	20	90	mNm	min.
stage materials	rotor housing bearing fasteners	stainless steel AISI316 anodised aluminium hardened steel (standard); full ceramic (-NM) stainless steel grade A4					
cable	length	1.5				m	± 0.1
	type	shielded cable, PFA insulation and sheat (standard/-HV) shielded cable, PFA insulation w/o sheat (-UHV)					

\* assuming a solid cylindrical payload of dia. 40 mm

### Controller/software

The XRT-U series rotation stages are compatible with all Xeryon controllers. Controlling of the stage is done with:

- Easy-to-use Windows interface
- LabVIEW interface program (compiled program or source)
- MATLAB interface script
- C++ and Python libraries

# Drawings

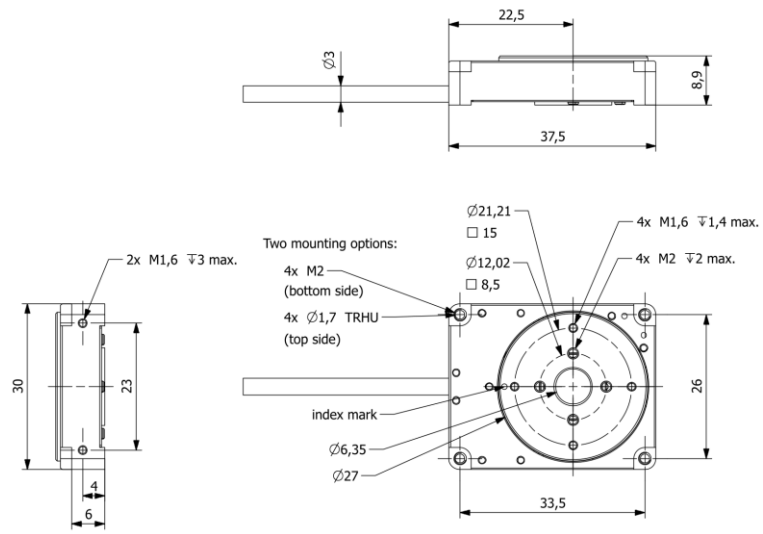

**XRT-U-25-assy A2**

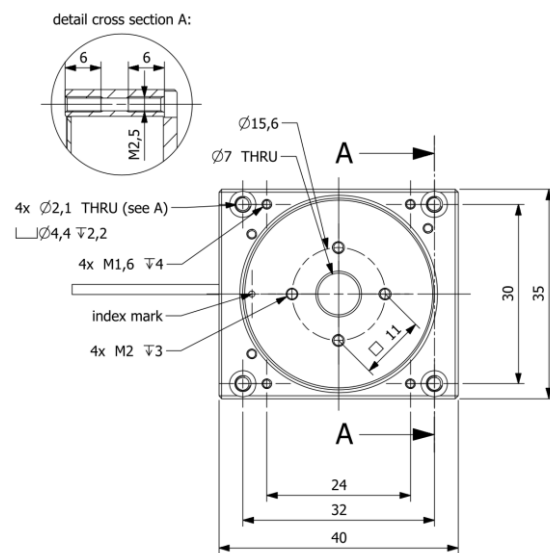
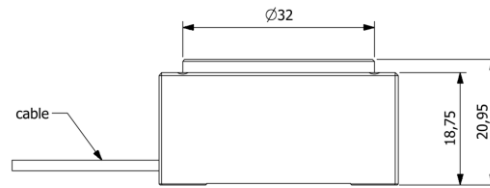

**XRT-U-30-assy O1**

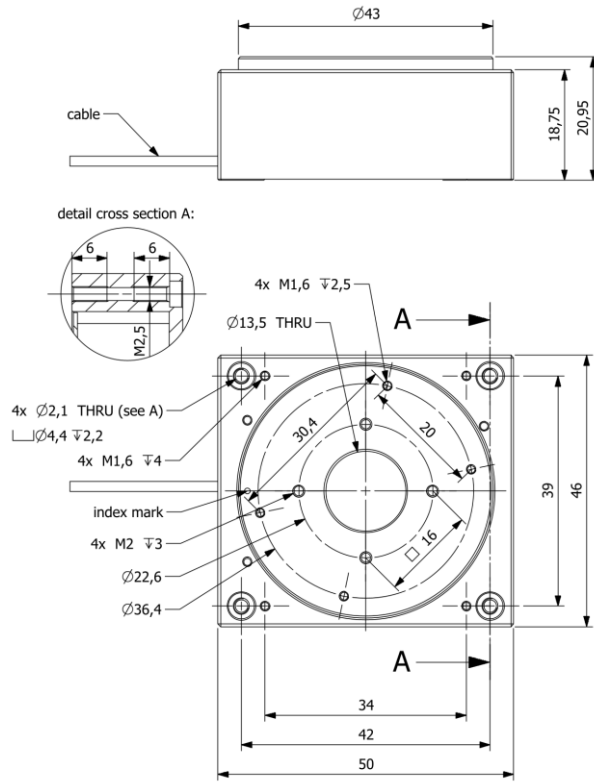

**XRT-U-40-assy M1**

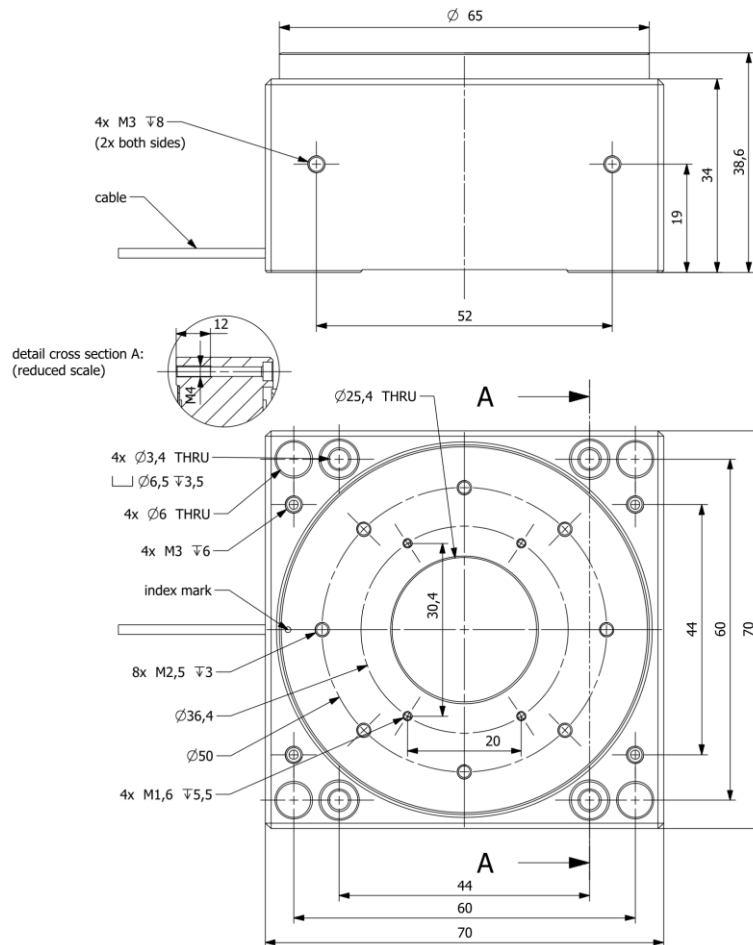

**XRT-U-60-assy F7**

recommended flatness of  
mounting surfaces: 20  $\mu\text{m}$  max.

	max. tightening torque
M1,6	16 cNm
M2	34 cNm
M2,5	60 cNm
M3	120 cNm

## Measurement data

---

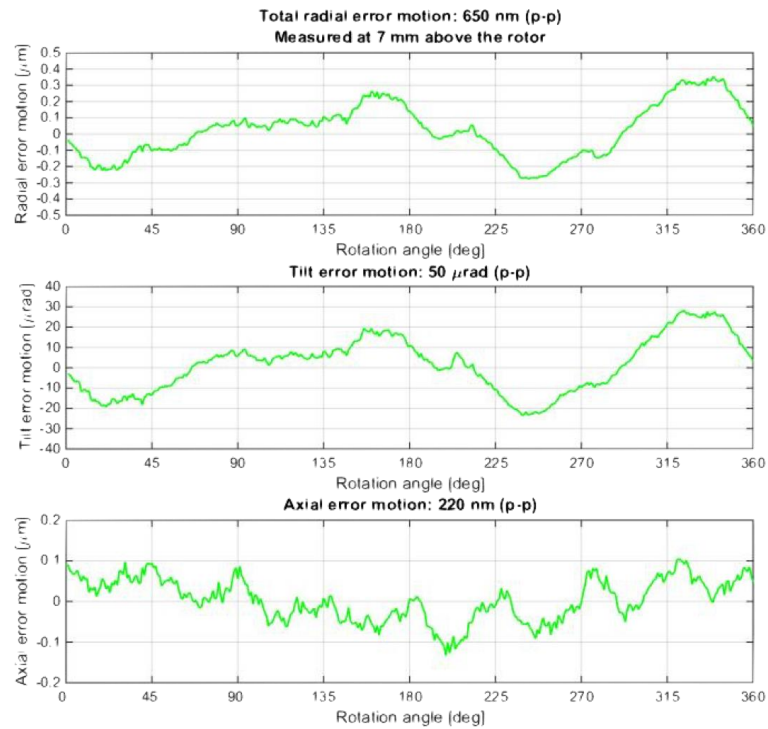

Typical measurement of the error motion of an XRT-U-30 rotation stage.

4 steps of 1° on a XRT-U-30-109 (no load).

DLAY=5 ms

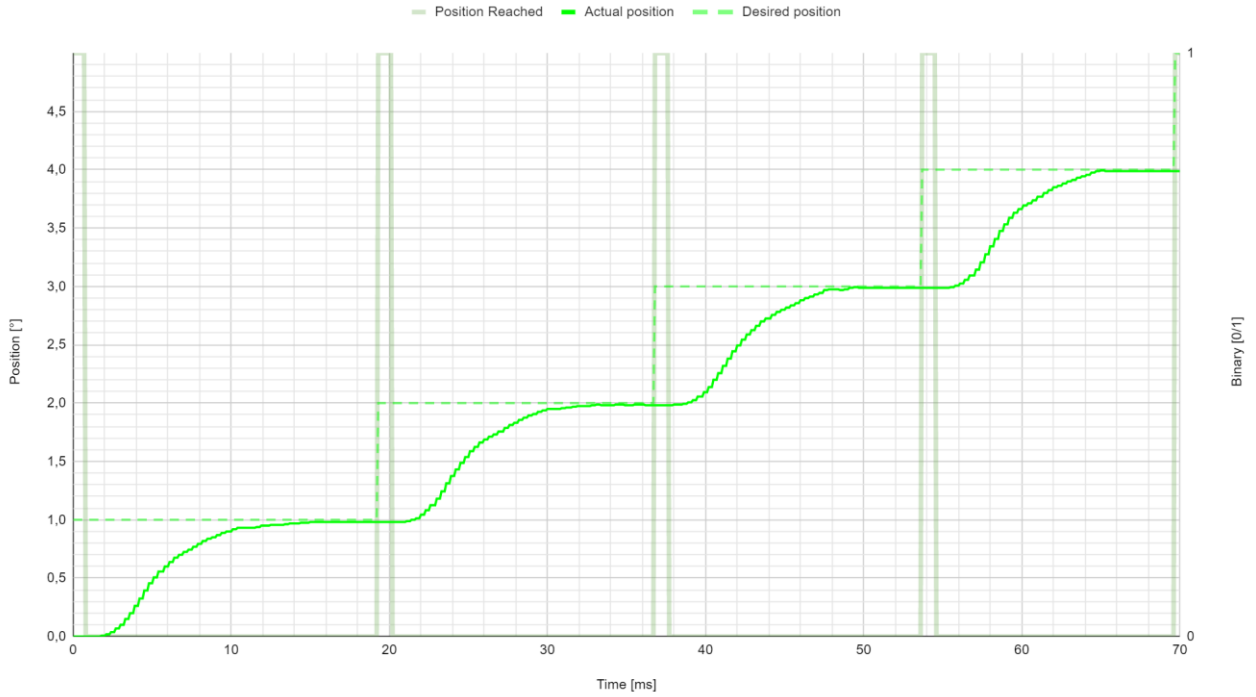

Example of an XRT-U-30-109 rotation stage without load taking steps of 1°. A delay of 5 ms is added between reaching the target position and taking the next step.

4 steps of 1° on a XRT-U-30-109 (load: inertia 65 kgmm<sup>2</sup>, mass 240 g)

DLAY=5 ms

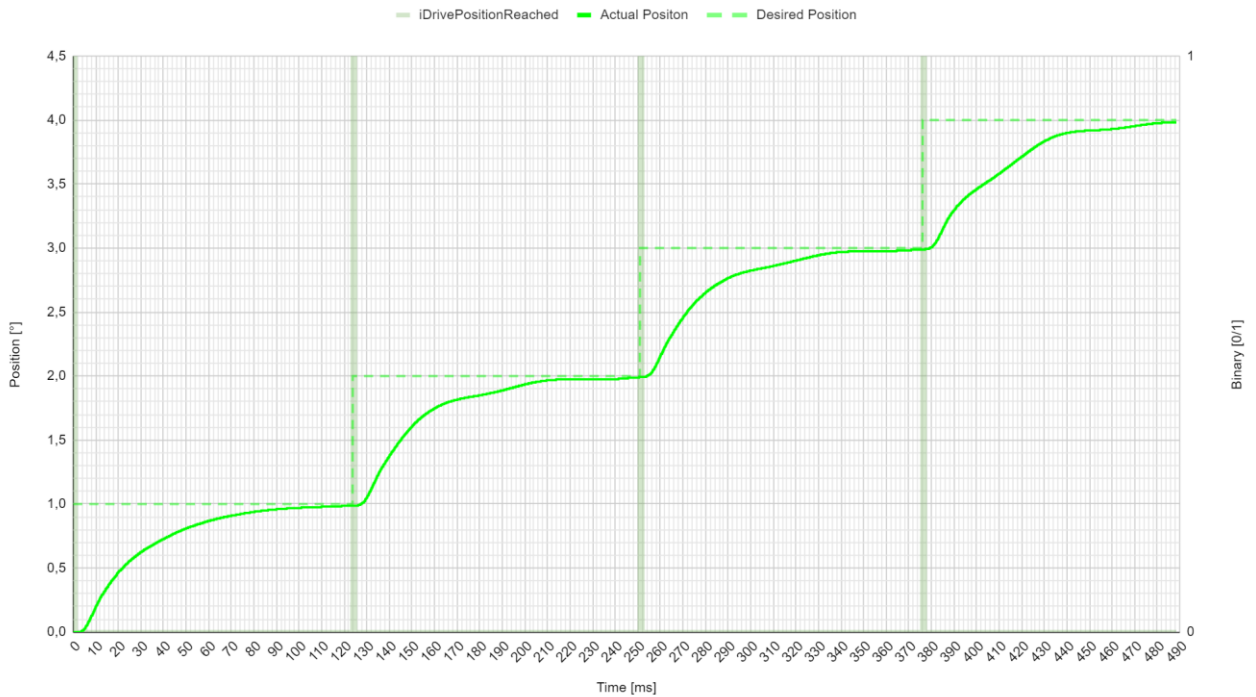

Example of an XRT-U-30-109 rotation stage with a load taking steps of 1°. A delay of 5 ms is added between reaching the target position and taking the next step.